

A Comprehensive Review of Hydraulic Systems in Aerospace and Construction Engineering

Sree Biddut Kumar ^{1,*}, Md Saim Hossem ², Abu Sayed ³

¹ Department of Mechanical Engineering, Hubei University of Automotive Technology, China

² Department of Mechanical Engineering, Nantong University, China

³ Department of Civil Engineering, Nantong University, China

Email: ¹ biddutkumar905@gmail.com, ² saimhossen289@gmail.com, ³ sayeddbber.2017@gmail.com

*Corresponding Author

Abstract—This paper provides a thorough examination of hydraulic systems used in construction and aerospace, emphasizing new developments and their vital functions in contemporary engineering. In the aircraft industry, where dependability at high altitudes is critical, hydraulic systems are essential for precise control over landing gear, flying surfaces, and brake systems. Fly-by-wire technology and advancements in lightweight materials, such as carbon fiber-reinforced plastics, have greatly improved system efficiency and decreased mechanical complexity, satisfying the exacting aerospace standards for accuracy, weight efficiency, and dependability. Hydraulic systems provide the force required for heavy lifting and earthmoving operations in a variety of settings, powering vital pieces of equipment such as excavators, cranes, and loaders in the construction industry. Performance, fuel economy, and safety have all increased as a result of recent developments, such as digital automation and energy-efficient designs. For instance, more automation and accuracy are now possible with electro-hydraulic controls, which lowers human effort and increases productivity on construction sites. Each sector's unique problems are also covered in this analysis, such as fluid dependability in harsh environments, system complexity, thermal management, and environmental issues including energy efficiency and fluid leakage. Future trends are examined in the assessment's conclusion, with a focus on sustainable practices such as energy-efficient designs and biodegradable hydraulic fluids. By focusing on these fields and developments, this research shows how hydraulic systems continue to propel industrial development, adjusting to intricate needs and advancing engineering applications' technical capabilities.

Keywords—Hydraulic Systems, Modern Engineering, Digital Controls, Environmental Impact, System Complexity, Thermal Management, Industry Advancement

I. INTRODUCTION

For many years, hydraulic systems have been a fundamental component of contemporary engineering, allowing for the powerful and accurate control of machines in a wide range of sectors [1]. Modern engineering has been built on hydraulic systems, which are essential for powering and managing equipment in sectors including manufacturing, construction, automotive, and aerospace. Their capacity to produce extreme power and precision has made them invaluable in situations where force and accuracy are critical. Since its original conception, the basic idea of hydraulics transmitting power via fluid pressure has remained unchanged [2], [3]. Despite their widespread use, hydraulic systems face several critical challenges, including environmental concerns over fluid leakage, the need for

energy-efficient designs, and the complexity of maintenance due to high system intricacies.

The function of hydraulic systems is becoming more widespread in the modern industrial environment [4]. Innovations such as electro-hydraulic controls and IoT-enabled systems offer promising solutions to these issues by enhancing precision, reducing human intervention, and enabling predictive maintenance [5], [6]. For example, electro-hydraulic systems enable more complex and automated processes by fusing the raw force of hydraulics with the accuracy of electronics. The automation and monitoring capabilities of hydraulic systems have been greatly enhanced by the integration of Internet of Things (IoT) platforms with Programmable Logic Controllers (PLCs) in terms of control technology. PLCs provide accurate control of hydraulic functions, guaranteeing reliable performance, while IoT connectivity makes remote diagnostics, predictive maintenance, and real-time monitoring possible. For example, IoT monitoring in heavy construction equipment aids in tracking hydraulic fluid use and operating efficiency, enabling modifications that lower fuel consumption and increase equipment longevity. Furthermore, IoT connectivity enables real-time remote monitoring, allowing ground crews to track the condition of hydraulic systems even while the aircraft is in flight.

In contemporary engineering applications, this mix of materials and intelligent control technologies is pushing hydraulic systems toward increased sustainability, dependability, and efficiency. In fields like aeronautical engineering, robotics, and automated manufacturing, where extreme accuracy and control are critical, this integration is particularly important [7], [8]. Hydraulic systems are found in many different sectors, which matches their adaptability. Cranes and other huge machinery in the construction and heavy machinery industries are powered by hydraulics [9]. They are essential to automotive systems like steering and braking because they provide the vehicle the force and responsiveness it needs to be controlled [10]. Meanwhile, hydraulics is used in medical equipment that ranges from patient lifts to surgical robots, where safety and accuracy are crucial. But as hydraulic technology develops, so do the difficulties it encounters.

Hydraulic system design and operation are increasingly being impacted by environmental considerations [11]. The design and operation of hydraulic systems are increasingly being influenced by environmental factors. These days,

problems including fluid leakage, hydraulic fluids' impact on the environment, and the need for energy efficiency are crucial. The industry is moving toward more sustainable methods in order to solve these issues. Developing biodegradable hydraulic fluids, implementing energy-efficient designs, and embracing the concepts of the circular economy are a few examples. The goals of these initiatives are waste reduction and better hydraulic component lifetime management [12].

This review is examine the developments, difficulties, and prospects for hydraulic systems in the fields of construction and aeronautical engineering. This research offers insights into how hydraulic systems are changing to satisfy the intricate requirements of contemporary engineering applications by looking at recent advancements including electro-hydraulic controllers, energy-efficient designs, and sustainable practices. The purpose of this study is to examine the developments, difficulties, and prospects for hydraulic systems in the fields of construction and aeronautical engineering. This research offers insights into how hydraulic systems are changing to satisfy the intricate requirements of contemporary engineering applications by looking at recent advancements including electro-hydraulic controllers, energy-efficient designs, and sustainable practices. Engineers and business professionals may more effectively use this potent instrument in their domains and guarantee that hydraulic technology plays a crucial part in the development of industry and technology by being aware of the present status of the field and its future. Aerospace hydraulic systems control landing gear, brakes, and flight surfaces, requiring high precision, weight efficiency, and reliability. Lightweight materials like carbon fiber-reinforced polymers and fly-by-wire technology enhance performance and reduce complexity. However, they face challenges from extreme conditions like high altitudes and temperature fluctuations, impacting fluid performance and reliability. The aim of this paper is to provide a thorough examination of hydraulic systems, taking into account current developments, obstacles, and potential future applications. Through an analysis of the customization of these systems to satisfy the specific requirements of each sector, this study will provide insights into the changing role of hydraulic technology in contemporary engineering.

II. MATERIALS FOR MICROGRID

systems employ liquids typically oil to convey power in a regulated way [13]. Because these systems can precisely and efficiently create, manage, and apply substantial pressures, they are highly appreciated in the engineering community. Studying the foundations of hydraulic systems include learning about their constituent parts, guiding principles, and the underlying physics concepts that control their operation [14]. These systems, which combine to turn mechanical force into hydraulic energy and vice versa, are made up of essential parts including hydraulic fluid, reservoirs, pumps, actuators, valves, and conduits [15]. Closed loop hydraulic systems circulate the fluid, while open loop hydraulic systems discharge the fluid into a reservoir after use. These systems' high power density, exact force and speed control, and built-in safety features including overload protection define how they operate.

Hydraulic systems consist of several core components pumps, actuators, valves, and reservoirs that work together to control and transmit hydraulic power. The hydraulic pump initiates the process by moving fluid from the reservoir, creating the pressure needed to drive actuators. This figure visually demonstrates the flow of hydraulic fluid and shows how components are interconnected to facilitate power transmission and control. The directional control valve, shown centrally in Fig. 1, is essential for guiding fluid flow to specific areas, allowing precise movement and force generation as needed in the system.

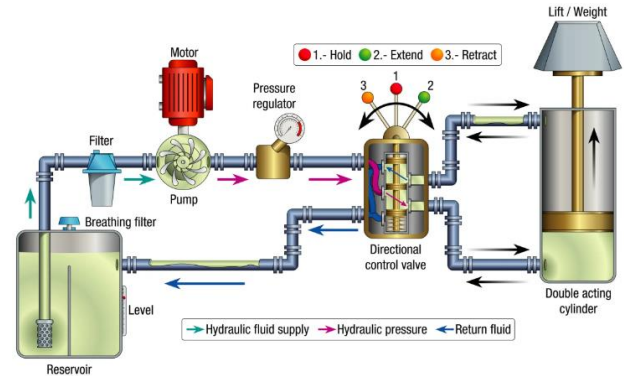

Fig. 1. Basic hydraulic working system

A. Pascal's Law

Hydraulic energy and power transmission is the practical use of Pascal's Law, which describes the uniform distribution of pressure in fluids, to produce and move energy within the system. Hydraulic systems can transfer energy over great distances by using this constant pressure, allowing for the strong and regulated movement needed for a variety of industrial applications. The most basic idea in fluid power, known as Pascal's law in physics, may be used to construct hydraulic systems [16]. The three primary components of hydraulic systems are the output, the control, and the power supply [17]. For example, in a hydraulic car lift, a small force applied to the fluid at one end is transmitted equally, producing a larger force at the lift platform, effectively raising vehicles. This demonstrates Pascal's Law, as varying the input and output cylinder areas allows designers to amplify force for efficient and controlled lifting. The force amplification based on Pascal's Law can be calculated using the formula,

$$F_2 = F_1 \times \frac{A_2}{A_1} \quad (1)$$

Where F_1 is the input force applied to an area A_1 , and F_2 is the resulting force in area A_2 .

The system's flow is supplied by the power supply component. It requires the transforms the actuator's mechanical power into fluid power. The connection between the theories of liquid matter and gaseous things, as well as the form changes between the two that led to the development of the hydrodynamic theory, make Pascal's law significant. One well-known use of Pascal's law is seen in hydraulic lifting equipment [18]. The technique is often employed in hydraulic systems, including hydraulic presses, lifts, and brakes, where it permits the application of a little force at one location to be multiplied and produce a much greater force at another [19],

[20]. The law emphasizes the homogeneity of a fluid's pressure distribution, which makes it essential to comprehending and developing a range of mechanical systems that use fluid power. The fundamental idea behind the uniform transmission of pressure in a confined fluid is provided by Pascal's Law. This concept lays the foundation for hydraulic energy and power transfer throughout the system and is crucial to comprehending how hydraulic systems effectively produce and manage force.

B. Hydraulic Energy and Power Transmission

In order to function, hydraulic systems need hydraulic power, which is the transfer of energy via pressured fluids. The first step in this process is to transform the mechanical energy that is stored in the pressured fluid into hydraulic energy. In this study, 'hydraulic power' will refer to the rate at which energy is transferred within the system, typically quantified as the product of force and flow rate. 'Hydraulic energy' will describe the potential or stored energy within the pressurized fluid, which drives the system's mechanical functions. The fluid's incompressibility makes it possible to transport energy across intricate system structures effectively and with little loss. Modern engineering relies heavily on hydraulic systems because they provide a strong and effective way to transfer power and energy by working with pressured fluids [21]. The fundamental idea behind how they work is that liquids can effectively transfer force over long distances and through intricate system configurations because they are incompressible. Because of this feature, hydraulic systems are essential in sectors including manufacturing, construction, aerospace, and automotive that need precise control and great power output [22]-[24].

The energy contained in the compressed fluid is the fundamental component of hydraulic energy. The equation $E = P \times V$, in which E stands for energy, P for pressure, and V for fluid volume. For example, a hydraulic press needs to exert a force on a 10 cubic meter fluid volume at a pressure of 500 kPa. Using $E = P \times V$, the energy stored in the fluid would be $E = 500,000 \text{ Pa} \times 10 \text{ m}^3 = 5,000,000 \text{ J}$. This energy can then be used to perform work, such as lifting or compressing materials. Hydraulic systems to determine the energy transmitted by taking into account the fluid volume and pressure. By calculating the energy needed to complete operations like transferring a load or extending a hydraulic cylinder, it aids in the design of efficient systems. Additionally, it is useful for monitoring system performance and optimizing fluid and pressure requirements to ensure safe and efficient operation. This connection demonstrates how variations in fluid pressure and volume have a direct effect on the workable energy [25]. Practically speaking, hydraulic systems transform hydraulic energy back into mechanical energy by using it to run equipment or move large objects.

This pressurized fluid's flow facilitates power transfer in hydraulic systems. The formula to compute the power communicated is $P = DF \times v$, where DF is the force the fluid exerts, v is the velocity at which the actuator or fluid flows, and P is the power. Hydraulic power has many different applications. For large weights, heavy gear in the construction industry, such excavators and cranes, depends on hydraulic systems. Hydraulics is used in manufacturing to provide forceful and accurate operations in presses and

injection molding machines. Hydraulic systems are essential to the functioning of landing gear and control surfaces in the aircraft sector [26]. They also improve the safety and performance of power steering and braking systems in automobile applications. Hydraulic systems are a complex example of how engineering and physics may be used to transfer large amounts of power effectively and precisely. Knowing the mechanics of these systems makes it possible to innovate and optimize industrial applications, guaranteeing that they will always be essential to the development of infrastructure and contemporary technology.

C. Hydraulic Fluid Dynamics

An essential component of hydraulic systems is hydraulic fluid dynamics, which is necessary to comprehend how these systems effectively transfer power and carry out tasks. Fundamentally, hydraulic fluid dynamics is concerned with the characteristics and behavior of fluids in motion, especially as they relate to the many hydraulic system components, including actuators, pumps, pipelines, valves, and valve covers. Because fluid dynamics affects system performance, efficiency, and design, it is important to research fluid dynamics in the context of hydraulics. Principles derived from the continuity equation and Bernoulli's equation control the flow of hydraulic fluid through a system. The pressure, velocity, and height of a fluid in motion are related by Bernoulli's equation, which aids in predicting the fluid's behavior at various pressure levels and flow rates [27]. For example, fluid is pushed under pressure from a reservoir into a cylinder via small pipes in a hydraulic lift system used in auto maintenance. The velocity often reduces with increasing temperature, making the fluid flow easier but perhaps lowering the layer thickness that shields components from wear. Lower temperatures, on the other hand, may cause the fluid to thicken, which would increase resistance and decrease flow efficiency. In order to maintain ideal viscosity and ensure smooth operation under a variety of climatic conditions, hydraulic systems need to include temperature controls, such as insulation or heat exchangers. A thorough understanding of hydraulic fluid dynamics is necessary to guarantee that the system operates as intended, maintaining the proper balance between fluid flow and pressure to transfer large loads safely and effectively. This formula is very helpful for building systems that need to precisely regulate fluid velocity and pressure in order to guarantee the smooth and effective operation of actuators and motors.

Conversely, the continuity equation states that unless there is a fluid input or output, the mass flow rate of a fluid must stay constant from one pipe cross-section to the next. This idea is crucial for keeping the hydraulic system balanced and for designing parts that can manage the anticipated flow rates without creating back pressure or turbulence, which may lower system performance [28]. Viscosity is another important component of hydraulic fluid dynamics that affects how well a fluid transmits power and resists flow. Higher viscosity fluids exhibit higher flow resistance, which may be useful in minimizing leaks and wear in hydraulic parts but may need more energy during pumping. Lower viscosity fluids, on the other hand, are simpler to pump but may provide less protection for components and be more prone to leaks. Viscosity is another way that temperature influences

fluid dynamics; when temperature rises, viscosity usually falls, which has an effect on the fluid's performance and the system's overall efficiency. As a result, maintaining the hydraulic fluid's ideal viscosity and avoiding system component damage depend heavily on temperature control.

Although fluid dynamics and sustainability are intimately related, hydraulic systems also need to handle efficiency issues and environmental effects. For instance, fluid leakage may contaminate the environment, and excessive energy use has an impact on emissions and operating expenses. To reduce their negative effects on the environment, modern hydraulic designs use elements like biodegradable fluids and energy-efficient component materials. Furthermore, by using variable displacement pumps, systems may optimize energy utilization and minimize needless fluid heating and wear by adjusting flow and pressure in response to demand. Hydraulic fluid dynamics plays a key role in maximizing the sustainability and performance of hydraulic systems by taking into account real-world elements including cavitation, turbulence, and friction. To guarantee dependable and sustainable hydraulic applications throughout sectors, engineers must strike a balance between fluid behavior, system demands, environmental effect, and energy efficiency.

III. CORE COMPONENTS OF HYDRAULIC SYSTEMS

The several essential parts of hydraulic systems each have a distinct purpose in the system's overall functioning. Main components of hydraulic components shown in Fig. 2. These parts include:

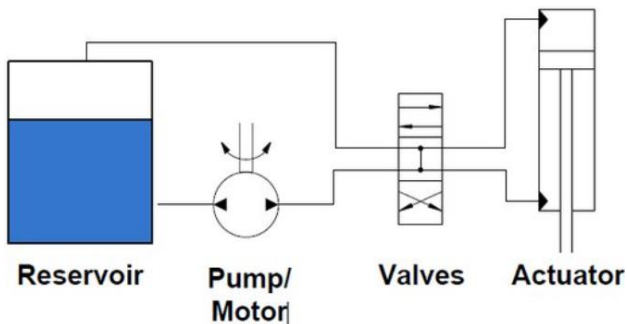

Fig. 2. Main components of hydraulic components [29]

- **Hydraulic Pump:** Any hydraulic system's pump is its central component. Through the system's movement of the hydraulic fluid, mechanical energy is transformed into hydraulic energy [30]. Pumps come in gear, vane, and piston varieties; depending on its efficiency, pressure capacity, and flow rate, each kind is best suited for a particular purpose.
- **Hydraulic Fluid:** The fluid, which is often oil, serves as a conduit for power transmission [31]. It also performs auxiliary functions in the system's sealing, cooling, and lubrication. The selection of hydraulic fluid is essential as it needs to be compatible with the components in the system, have the proper viscosity, and be thermally stable.
- **Valves:** Within the hydraulic system, valves regulate the hydraulic fluid's pressure, flow rate, and direction. Flow control, pressure relief, and direction control valves are some examples of valve types [32]. These parts are

necessary to control how the system works and guarantee that the intended force or motion is applied.

- **Actuators:** Actuators transform hydraulic energy back into mechanical energy. Examples of actuators are hydraulic cylinders and motors [33]. Hydraulic motors provide rotating motion that is helpful for moving wheels or other equipment, while cylinders create linear motion that is often utilized in lifting or pressing applications.
- **Reservoir:** The reservoir aids in heat dissipation and stores extra hydraulic fluid. It also contributes to the fluid's overall lifespan and efficiency by enabling impurities to settle and isolating air from the fluid [34].

A. Operating Principles of Hydraulic Systems

Fluid dynamics fundamentals, of which Pascal's Law is the most fundamental, control how a hydraulic system operates [35]. According to Pascal's Law, pressure is transferred equally in all directions when it is applied to a confined fluid. Hydraulic systems' ability to increase force or regulate movement is based on this idea. Within a normal hydraulic system:

- **Relationship between Pressure and Flow:** The system pressure is determined by the load pressure, which acts as resistance to the flow produced by the pump. The system's functioning is based on the relationship between flow (Q), pressure (P), and the power provided by the system ($Power = Pressure \times Flow$).
- **Relationship between Force and Area:** A hydraulic actuator's force is exactly proportional to the pressure it applies and the piston's area. The formula for determining the necessary pressure for a job is $Force = Pressure \times Area$.
- **Control of Motion:** The actuator's speed is determined by the hydraulic fluid flow rate, and the force or torque generated is determined by the hydraulic fluid pressure. The output of the system may be precisely controlled by varying these parameters using valves. Numerous industries, including manufacturing, aerospace, automotive, and construction, use the basic concepts of hydraulics [36]. The fundamental concepts of pressure, flow, and force are employed to provide accurate and dependable results in a variety of jobs, from simple ones like lifting large objects to more complicated ones like managing an aircraft's flying surfaces [37]. By comprehending these principles, engineers may create and use hydraulic systems that are powerful and efficient, able to carry out a variety of tasks with the requisite accuracy.

IV. INDUSTRY SPECIFIC APPLICATIONS AND INNOVATIONS

Many different sectors rely heavily on hydraulic systems, and they all use the technology to suit unique operating requirements [38]. Hydraulic systems are very useful in a variety of industries, from heavy equipment to renewable energy, due to their versatility and strength [39]. This section examines the many uses of hydraulics in various sectors and emphasizes the most current advancements that are advancing these uses.

- **Construction and Heavy Machinery:** Because they provide the power required to run machines like

excavators, loaders, cranes, and bulldozers, hydraulic systems are essential to the construction and heavy machinery sectors [40]. Large weights can be moved precisely and effectively with the help of these systems, which makes them invaluable for jobs like lifting and earthmoving even in tight spaces [41], [42]. Energy recovery systems in contemporary excavators, which catch and repurpose energy during braking or lowering operations, greatly reduce fuel usage, are one example of how recent advances have expanded their function. Furthermore, improvements in electro-hydraulic controls have increased automation and accuracy, enabling operators to do difficult jobs with less human labor, enhancing productivity and safety on building sites [43]. Hydraulic systems continue to be at the forefront of construction evolution, spurring innovation and enabling more sophisticated and environmentally friendly operations. Hydraulic systems are necessary in the construction sector to run large equipment like bulldozers, loaders, and excavators. For example, a hydraulic excavator effectively controls high forces with little human input by amplifying force using Pascal's Law. The boom, arm, and bucket are extended and retracted by actuators using the pressurized fluid from the hydraulic pump.

- **Automotive Industry:** In the automotive sector, hydraulic systems are vital because they perform vital tasks that improve the efficiency, safety, and performance of vehicles [44]. They are essential for accurate control and seamless functioning in parts like automated gearboxes, power steering, and brake systems. By transforming the force placed on the brake pedal into hydraulic pressure, which then contacts the brake pads, hydraulic brakes, for instance, provide dependable stopping power [45]. Hydraulics is also used by power steering systems to improve steering responsiveness and ease of operation, especially at low speeds. The development of electro-hydraulic systems, which combine the accuracy of electronic controls with the dependability of hydraulics to increase driving dynamics and fuel economy, is one recent breakthrough in automobile hydraulics. Hydraulic systems continue to be essential to performance and innovation in the car industry. The purpose of hydraulic braking systems is to provide dependable stopping force by use of hydraulic energy transfer and Pascal's Law. The hydraulic system's braking fluid is pressurized when a driver applies pressure to the master cylinder via the brake pedal. Through brake lines, this pressurized fluid makes its way to the brake calipers on each wheel, where it increases the force exerted on the brake pads and presses them up against the rotors to slow or stop the car. The technology improves vehicle stability and safety by applying a consistent braking force to all wheels via the use of hydraulic pressure.
- **Aerospace Engineering:** Aerospace engineers depend heavily on hydraulic systems because they provide the power and control required for vital aircraft tasks. Among other systems, they control thrust reversers, landing gear, brakes, and flight control surfaces. In aircraft applications, where weight and space are limited,

hydraulics' ability to provide tremendous power with fine control in a relatively small and lightweight form makes them perfect [46]. In order to improve performance and dependability, modern airplanes often use sophisticated electro-hydraulic systems that combine hydraulic mechanics with electronic controls. Even with heavy weights, aircraft landing gear can smoothly retract and expand thanks to hydraulic actuators. Actuators in the landing gear assembly receive the pressurized hydraulic fluid from the hydraulic pump during takeoff. These actuators raise and lower the gear into the aircraft body using the pressurized fluid. The actuators are used to extend the landing gear and support the weight of the aircraft as it lands. Since the system must manage the tremendous forces during deployment as well as the steadiness needed for landing, precision is essential.

Modern airplanes are now safer and more efficient thanks to innovations like fly-by-wire technology, which utilizes electrical impulses to operate hydraulic actuators [47]. Hydraulic systems remain essential as aeronautical engineering develops, propelling improvements in aircraft operation and design.

- **Renewable Energy:** In the field of renewable energy, hydraulic systems are becoming more and more significant, especially in wind and hydropower applications. Hydraulics are employed in wind turbines to regulate the pitch and yaw of the blades, maximizing energy absorption and shielding the turbine from damage during strong winds [48]. Hydraulic actuators improve the blade's exposure to wind by varying the blade angle, or pitch, which may reduce burden during strong winds or maximize energy collection. The nacelle, which houses the turbine's components, is rotated by hydraulic yaw controls to match the direction of the wind. Because improper blade orientation might lower energy efficiency or harm the turbine, this application requires precision control. Here, the continuity equation is essential because it guarantees a steady flow rate to preserve the intended blade angle. As an example of how hydraulic systems facilitate effective and flexible energy production in renewable applications, operators may modify hydraulic parameters in real-time depending on wind conditions via remote monitoring and IoT integration. For maximum efficiency, these parts must be able to be precisely adjusted in reaction to changing wind conditions. Hydraulic systems control the water flow via turbines in hydropower facilities, effectively transforming the kinetic energy of the water into electrical energy [49]. Furthermore, hydraulic systems aid in the conversion of ocean energy into useful power in tidal and wave energy converters. Hydraulic systems' dependability and effectiveness are crucial for propelling the development of sustainable energy solutions as the renewable energy sector grows.

V. CHALLENGES AND LIMITATIONS OF HYDRAULIC SYSTEMS

Despite its great efficacy and widespread use, hydraulic systems do have some limitations and problems. It is essential to comprehend them in order to ensure the proper design, operation, and maintenance of hydraulic systems. Some of

the most significant issues and constraints associated with hydraulic systems are as follows:

- Seals and connectors are essential to hydraulic systems' ability to retain fluid and sustain pressure. Fluid leaks from worn-out seals may lower system efficiency and pose environmental hazards. The fluid may be weakened by impurities like dirt, water, or air, which can lead to malfunctions, a reduced component lifetime, and decreased performance.
- These systems are complicated because they often include a large number of parts, including hoses, cylinders, pumps, and valves. This intricacy may make troubleshooting and maintenance more difficult, requiring frequent maintenance that can be costly and time-consuming in order to maintain smooth performance.
- Hydraulic systems can generate considerable heat, particularly with heavy loads. This overheating can damage components, lower performance, and degrade the fluid. Implementing effective cooling systems is necessary to manage this heat, increasing system complexity and cost.
- Temperature variations may affect hydraulic fluids, which can affect system performance. High temperatures have the potential to break down the fluid and increase the danger of system failure, while low temperatures may thicken the fluid and cause slow operation.
- Comparatively speaking to other systems, such as electric systems, hydraulic systems may be less energy-efficient. Friction, fluid resistance, and heat creation all result in energy losses, which may be problematic in situations where energy conservation is essential.
- Hydraulic systems may be large and heavy, particularly those designed for high-pressure uses. This may restrict their employment in scenarios where weight and space are crucial limitations, such as in aeronautical or mobile equipment.

VI. CONCLUSION

This paper provides a comprehensive examination of hydraulic systems, highlighting their critical role across various industries such as construction, automotive, aerospace, and renewable energy. Key findings indicate that hydraulic systems leverage fundamental principles, such as Pascal's Law and the continuity equation, to achieve efficient power transmission and precise control. The design and operation of hydraulic systems still face a number of difficulties, nevertheless. Efficiency and dependability are greatly impacted by problems such as fluid cavitation, turbulence, and frictional losses. In order to overcome these obstacles, fluid behavior under various pressure and temperature circumstances must be carefully considered. Additionally, contemporary technology must be used to reduce hazards.

In today's engineering, hydraulic systems are essential because they provide unparalleled accuracy and power in demanding applications across many sectors. The need for ever-higher performance and control in industries including manufacturing, aerospace, and construction is propelling their rapid progress. Modern materials, sophisticated digital controls, and game-changing technologies like the Internet of Things (IoT) and artificial intelligence (AI) have all been

incorporated into these systems to elevate them to the forefront of industrial innovation while simultaneously improving their efficiency and adaptability. Hydraulic systems are essential to the functioning of equipment in a variety of industries, including aerospace and construction, but they also confront new difficulties, mainly with regard to energy efficiency and environmental sustainability. The design and operation of hydraulic systems are increasingly being influenced by environmental factors. These days, problems including fluid leakage, hydraulic fluids' impact on the environment, and the need for energy efficiency are crucial. The industry is moving toward more sustainable methods in order to solve these issues. Developing biodegradable hydraulic fluids, implementing energy-efficient designs, and embracing the concepts of the circular economy are a few examples. The goals of these initiatives are waste reduction and better hydraulic component lifetime management. The future of hydraulic systems will be greatly influenced by the incorporation of digital technology and sustainable practices. Hydraulic systems will continue to be an essential part of contemporary engineering solutions, satisfying the expanding needs of many sectors, thanks to the continuous dedication to addressing efficiency and environmental concerns.

REFERENCES

- [1] R. S. Gupta, "Hydrology and hydraulic systems," *Waveland Press*, , 2016, https://books.google.co.id/books/about/Hydrology_and_Hydraulic_Systems.html?id=ci1XvgAACAAJ&redir_esc=y.
- [2] Q. Zhang, X. Kong, B. Yu, K. Ba, Z. Jin, Y. Kang, "Review and development trend of digital hydraulic technology," *Applied Sciences*, vol. 10, no. 2, p. 579, 2020, <https://doi.org/10.3390/app10020579>.
- [3] A. R. Behbahani, and K. J. Semega, "Control strategy for electro-mechanical actuators versus hydraulic actuation systems for aerospace applications," *SAE Technical Paper*, 2010, <https://doi.org/10.4271/2010-01-1747>.
- [4] W. Burget, J. Weber, "Mobile systems-markets, industrial needs and technological trends," *8th International Fluid Power Conference (IFK)*, vol. 2, pp. 23-54, 2012, https://gfpsweb.org/sites/default/files/external_pages/IFK_2012/Group1_files/1.0_Weber.pdf.
- [5] Sumit *et al.*, "Energy saving implementation in hydraulic press using industrial Internet of Things (IIoT)," *Electronics*, vol. 11, no. 23, p. 4061, 2022, <https://doi.org/10.3390/electronics11234061>.
- [6] X. Zhou, and X. Lei, "Fault diagnosis method of the construction machinery hydraulic system based on artificial intelligence dynamic monitoring," *Mobile Information Systems*, vol. 2021, no. 1, pp. 1-10, 2021, <https://doi.org/10.1155/2021/1093960>.
- [7] Z. Liu, J. Sun, D. Yue, X. Zuo, H. Gao, and K. Feng, "A review on integral evolution of electro-hydraulic actuation in three momentous domains: aerospace, engineering machinery, and robotics," *Fourth International Conference on Mechanical Engineering, Intelligent Manufacturing, and Automation Technology*, vol. 13082, pp. 141-159, 2024, <https://doi.org/10.1117/12.3026210>.
- [8] R. Brandstetter, T. Deubel, R. Scheidl, B. Winkler, and K. Zeman, "Digital hydraulics and "Industrie 4.0"," *Proceedings of the Institution of Mechanical Engineers, Part I: Journal of Systems and Control Engineering*, vol. 231, no. 2, pp. 82-93, 2017, <https://doi.org/10.1177/0959651816636734>.
- [9] T. Lin, Q. Chen, H. Ren, W. Huang, Q. Chen, and S. Fu, "Review of boom potential energy regeneration technology for hydraulic construction machinery," *Renewable and Sustainable Energy Reviews*, vol. 79, pp. 358-371, 2017, <https://doi.org/10.1016/j.rser.2017.05.131>.
- [10] W. A. Smith, N. Zhang, and W. Hu, "Hydraulically interconnected vehicle suspension: handling performance," *Vehicle System Dynamics*, vol. 49, no. 1-2, pp. 87-106, 2011, <https://doi.org/10.1080/00423111003596743>.

- [11] Y. Tanaka, S. Sakama, and R. Suzuki, "Bubble elimination from working oil for environmentally friendly hydraulic system design," *International Journal of Automation Technology*, vol. 6, no. 4, pp. 1-6, 2012, <https://doi.org/10.20965/ijat.2012.p0488>.
- [12] Z. Tkáč *et al.*, "Research of biodegradable fluid impacts on operation of tractor hydraulic system," *Acta technologica agriculturae*, vol. 20, no. 2, pp. 42-45, 2017, <https://doi.org/10.1515/ata-2017-0008>.
- [13] W. Durfee, Z. Sun, and J. V. D. Van, "Fluid power system dynamics," *Center for Compact and Efficient Fluid Power*, 2009, <https://oylair.com/wp-content/uploads/2021/03/resources-library-2-fluid-power-system-dynamics.pdf>.
- [14] D. Li *et al.*, "Investigation methods for analysis of transient phenomena concerning design and operation of hydraulic-machine systems—A review," *Renewable and Sustainable Energy Reviews*, vol. 101, pp. 26-46, 2019, <https://doi.org/10.1016/j.rser.2018.10.023>.
- [15] P. Novak, V. Guinot, A. Jeffrey, and D. E. Reeve, "Hydraulic modelling: An introduction: Principles, methods and applications," *CRC Press*, p. 616, 2010, <https://doi.org/10.1201/9781315272498>.
- [16] B. A. Gyamfi, F. F. Adedoyin, M. A. Bein, F. V. Bekun, D. Q. Agozie, "The anthropogenic consequences of energy consumption in E7 economies: juxtaposing roles of renewable, coal, nuclear, oil and gas energy: evidence from panel quantile method," *Journal of Cleaner Production*, vol. 295, p. 126373, 2021, <https://doi.org/10.1016/j.jclepro.2021.126373>.
- [17] C. Majidi, "Soft-matter engineering for soft robotics," *Advanced Materials Technologies*, vol. 4, no. 2, p. 1800477, 2019, <https://doi.org/10.1002/admt.201800477>.
- [18] R. Maryanti, A. Hufad, S. Sunardi, and A. B. D. Nandiyanto, "Teaching on Pascal's Law: The use of experimental videos of hydraulic concepts from everyday products in the learning process for students with special needs and vocational school students," *Journal of Engineering Education Transformations*, vol. 35, no. 2, pp. 96-101, 2022, <https://dx.doi.org/10.16920/jeet/2022/v35is2/22119>.
- [19] R. A. Anugrah, and P. Rachmawati, "February. Analysis of Hydraulic System on Portable Electrical Hydraulic Jack," *Proceedings of the 4th International Conference on Sustainable Innovation 2020—Technology, Engineering and Agriculture (ICoSITA 2020)*, pp. 203-208, 2021, <https://doi.org/10.2991/aer.k.210204.037>.
- [20] Y. Rastogi, P. Shishodiya, S. K. Singh, S. Kumar, V. K. Saini, "A review on design of hydraulic disc brakes, calculations and design," *International Journal of Advance Research and Development*, vol. 3, no. 5, pp. 17-23, 2018, <https://www.ijarnd.com/manuscripts/v3i5/V3I5-1156.pdf>.
- [21] T. H. Ho, and K. K. Ahn, "Modeling and simulation of hydrostatic transmission system with energy regeneration using hydraulic accumulator," *Journal of mechanical science and technology*, vol. 24, pp. 1163-1175, 2010, <https://doi.org/10.1007/s12206-010-0313-8>.
- [22] M. Bertolin, and A. Vacca, "An energy efficient power-split hybrid transmission system to drive hydraulic implements in construction machines," *Journal of Dynamic Systems, Measurement, and Control*, vol. 143, no. 10, p. 101005, 2021, <https://doi.org/10.1115/1.4051035>.
- [23] D. B. Jani *et al.*, "An overview on aircraft hydraulic system," *International Journal of Innovative Research in Technology*, vol. 6, no. 5, pp. 6-10, 2019, https://ijirt.org/publishedpaper/IJIRT157626_PAPER.pdf.
- [24] R. Rădoi, C. Dumitrescu, I. David, M. Blejan, Ș. Șefu, C. Ionescu, "Utility vehicle with hydraulic transmission and hybrid energy source," *Mining Machines*, vol. 41, no. 1, pp. 1-10, 2023, <https://doi.org/10.32056/KOMAG2023.1.1>.
- [25] J. G. Venegas, R. S. Harris, and B. A. Simon, "A comprehensive equation for the pulmonary pressure-volume curve," *Journal of applied physiology*, vol. 84, no. 1, pp. 389-395, 1998, <https://doi.org/10.1152/jappl.1998.84.1.389>.
- [26] I. Raouf, P. Kumar, Y. Cheon, M. Tanveer, S. H. Jo, and H. S. Kim, "Advances in Prognostics and Health Management for Aircraft Landing Gear—Progress, Challenges, and Future Possibilities," *International Journal of Precision Engineering and Manufacturing-Green Technology*, pp. 1-20, 2024, <https://doi.org/10.1007/s40684-024-00646-4>.
- [27] F. Pfeiffer, and F. Borchsenius, "New hydraulic system modelling," *Journal of Vibration and Control*, vol. 10, no. 10, pp. 1493-1515, 2004, <https://doi.org/10.1177/1077546304042063>.
- [28] W. Rodi, "Turbulence modeling and simulation in hydraulics: A historical review," *Journal of Hydraulic Engineering*, vol. 143, no. 5, p. 03117001, 2017, [https://doi.org/10.1061/\(ASCE\)HY.1943-7900.0001288](https://doi.org/10.1061/(ASCE)HY.1943-7900.0001288).
- [29] P. Ranjan, N. P. Choudhry, "Design and finite element analysis of double-acting, double-ends hydraulic cylinder for industrial automation application," *International Research Journal of Modernization in Engineering Technology and Science*, vol. 05, no. 12, pp. 1829-1836, 2023, https://www.irjmets.com/uploadedfiles/paper/issue_12_december_2023/47440/final/fin_irjmets1703130948.pdf.
- [30] Y. Yang, L. Ding, J. Xiao, G. Fang, and J. Li, "Current status and applications for hydraulic pump fault diagnosis: A review," *Sensors*, vol. 22, no. 24, p. 9714, 2022, <https://doi.org/10.3390/s22249714>.
- [31] S. A. Faroughi, A. J. J. Pruvot, and J. McAndrew, "The rheological behavior of energized fluids and foams with application to hydraulic fracturing," *Journal of Petroleum Science and Engineering*, vol. 163, p. 243-263, 2018, <https://doi.org/10.1016/j.petrol.2017.12.051>.
- [32] G. Coskun, T. Kolcuoglu, T. Dogramaci, A. C. Turkmen, C. Celik, and H. S. Soyhan, "Analysis of a priority flow control valve with hydraulic system simulation model," *Journal of the Brazilian Society of Mechanical Sciences and Engineering*, vol. 39, pp. 1597-1605, 2017, <https://doi.org/10.1007/s40430-016-0691-7>.
- [33] J. Skowrońska, A. Kosucki, and Ł. Stawiński, "Overview of materials used for the basic elements of hydraulic actuators and sealing systems and their surfaces modification methods," *Materials*, vol. 14, no. 6, p. 1422, 2021, <https://doi.org/10.3390/ma14061422>.
- [34] A. Wohlers, A. Backes, and D. Schönfeld, "An approach to optimize the design of hydraulic reservoirs," *10th International Fluid Power Conference*, vol. 1, pp. 609-618, 2016, <https://tud.qucosa.de/landing-page/https%3A%2F%2Ftud.qucosa.de%2Fapi%2Fqucosa%253A29338%2Fmets%2F?L=1>.
- [35] I. Farida, R. Kheiriah, S. Sari and F. S. Irwansyah, "Application of the principle of hydraulic cranes on the conductivity tester," *Journal of Physics: Conference Series*, vol. 1402, no. 5, p. 055072, 2019, <https://doi.org/10.1088/1742-6596/1402/5/055072>.
- [36] B. Xu, J. Shen, S. Liu, Q. Su & J. Zhang, "Research and development of electro-hydraulic control valves oriented to industry 4.0: a review," *Chinese Journal of Mechanical Engineering*, vol. 33, no. 29, pp. 1-20, 2020, <https://doi.org/10.1186/s10033-020-00446-2>.
- [37] W. Schäfer *et al.*, "Good urodynamic practices: uroflowmetry, filling cystometry, and pressure-flow studies," *Neurourology and Urodynamics*, vol. 21, no. 3, pp. 261-274, 2002, <https://doi.org/10.1002/nau.10066>.
- [38] F. Sciatti, P. Tamburrano, E. Distaso and R. AmiranteSciatti, "Digital hydraulic technology: applications, challenges, and future direction," *Journal of Physics: Conference Series*, vol. 2648, p. 012053, 2023, <https://doi.org/10.1088/1742-6596/2648/1/012053>.
- [39] I. Yüksel, "Hydropower for sustainable water and energy development," *Renewable and Sustainable Energy Reviews*, vol. 14, no. 1, pp. 462-469, 2010, <https://doi.org/10.1016/j.rser.2009.07.025>.
- [40] L. Darko, T. Vito, "Speed-controlled hydraulic drive systems for heavy machinery," *IMK-14-Istrazivanje i razvoj*, vol. 27, no. 2, pp. 61-72, 2021, <https://doi.org/10.5937/IMK2102061L>.
- [41] S. Dadhich, U. Bodin, and U. Andersson, "Key challenges in automation of earth-moving machines," *Automation in construction*, vol. 68, pp. 212-222, 2016, <https://doi.org/10.1016/j.autcon.2016.05.009>.
- [42] R. Mitrev, and D. Marinković, "Numerical study of the hydraulic excavator overturning stability during performing lifting operations," *Advances in Mechanical Engineering*, vol. 11, no. 5, 2019, <https://doi.org/10.1177/1687814019841779>.
- [43] D. H. Autor, "Why are there still so many jobs? The history and future of workplace automation," *Journal of economic perspectives*, vol. 29, no. 3, pp. 3-30, 2015, <https://doi.org/10.1257/jep.29.3.3>.
- [44] L. Pugi *et al.*, "Fast modelling and identification of hydraulic brake plants for automotive applications," *International Journal of Fluid Power*, vol. 21, no. 2, pp. 169-210, 2020, <https://doi.org/10.13052/ijfp.1439-9776.2122>.
- [45] S. Ward, "Digital hydraulics in aircraft control surface actuation: Modelling and evaluation of digital hydraulic systems with focus on performance and energy efficiency," *Digitala Vetenskapliga Arkivet*,

- 2017, <https://www.diva-portal.org/smash/record.jsf?pid=diva2%3A1261126&dswid=4169>.
- [46] G. J. Harloff, and B. M. Berkowitz, "HASA: Hypersonic aerospace sizing analysis for the preliminary design of aerospace vehicles," NASA, 1988, <https://ntrs.nasa.gov/api/citations/19890005736/downloads/19890005736.pdf>.
- [47] I. Moir, and A. Seabridge, R. Langton, "Aircraft Systems: Mechanical, electrical, and avionics subsystems integration, 3rd Edition," John Wiley & Sons, 2011, <https://www.wiley.com/en-us/Aircraft+Systems%3A+Mechanical%2C+Electrical%2C+and+Avionics+Subsystems+Integration%2C+3rd+Edition-p-9781119965206>.
- [48] R. I. Pelin, P. D. Bârsănescu, and I. Tița, "Hydraulic systems used for pitch control of wind turbines: a literature overview," *IOP Conference Series: Materials Science and Engineering*, vol. 444, no. 4, p. 042013, 2018, <https://doi.org/10.1088/1757-899X/444/4/042013>.
- [49] M. A. Halim, M. M. Hossain, and M. J. Nahar, "Development of a Nonlinear Harvesting Mechanism from Wide Band Vibrations," *International Journal of Robotics and Control Systems*, vol. 2, no. 3, pp. 467-476, 2022, <https://doi.org/10.31763/ijrcs.v2i3.524>.